

FORMA D'ATTACCO TIPO "C"

Sull'asse del rullo viene effettuata una lavorazione di tornitura e filettatura esterna per il fissaggio alla struttura.

TYPE "C" COUPLING FORM

A turning and external threading operation is carried out on the roller shaft for fixing it to the structure.

FORMA C C TYPE	SERIE SERIES YP-YA 2006	SERIE SERIES YP-YA 3008	SERIE SERIES YP-YA 4008	SERIE SERIES YP-YA 5008	SERIE SERIES YP-YA 4010	SERIE SERIES YP-YA 5010
D	20	30	40	50	40	50
G	19	22	22	23,5	24	25,5
C	2	2	2	3,5	2	3,5
E	17	20	20	20	22	22
M	6	8	8	8	10	10

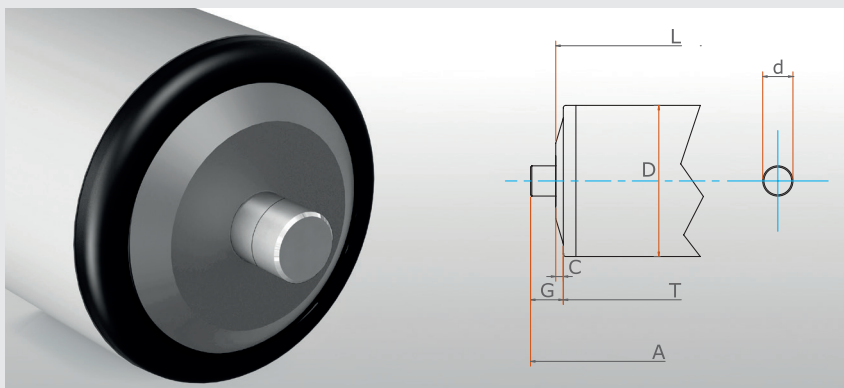

FORMA D'ATTACCO TIPO "D"

Sull'asse del rullo viene lasciata una sporgenza in modo da permettere il fissaggio alla struttura.

TYPE "D" COUPLING FORM

A projection is left on the roller shaft in such a way as to allow it to be fixed to the structure.

FORMA C C TYPE	SERIE SERIES YP-YA 2006	SERIE SERIES YP-YA 3008	SERIE SERIES YP-YA 4008	SERIE SERIES YP-YA 5008	SERIE SERIES YP-YA 4010	SERIE SERIES YP-YA 5010
D	20	30	40	50	40	50
d	6	8	8	8	10	10
G	8	10	10	11,5	12	13,5
C	2	2	2	3,5	2	3,5

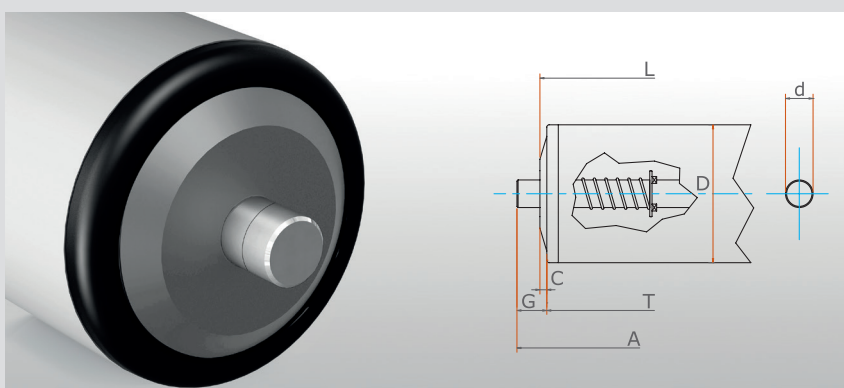

FORMA D'ATTACCO TIPO "E"

Asse retrattile per consentire il fissaggio alla struttura.

TYPE "E" COUPLING FORM

A retractable shaft to permit fixing to the structure.

FORMA E E TYPE	SERIE SERIES YP-YA 2006	SERIE SERIES YP-YA 3008	SERIE SERIES YP-YA 4008	SERIE SERIES YP-YA 5008	SERIE SERIES YP-YA 4010	SERIE SERIES YP-YA 5010
D	20	30	40	50	40	50
d	6	8	8	8	10	10
G	8	10	10	11,5	12	13,5
C	2	2	2	3,5	2	3,5